

# Corian® Specification Sheet : 4222 Washplane

## Notes:

Tap hole cutouts not included, drawing for location reference only.  
 All exposed edges sanded to 2mm radius.  
 All exposed surface sanded to semi-gloss finish.  
 Net weight: 60 Kgs

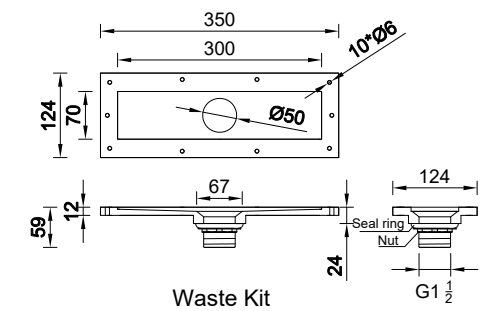
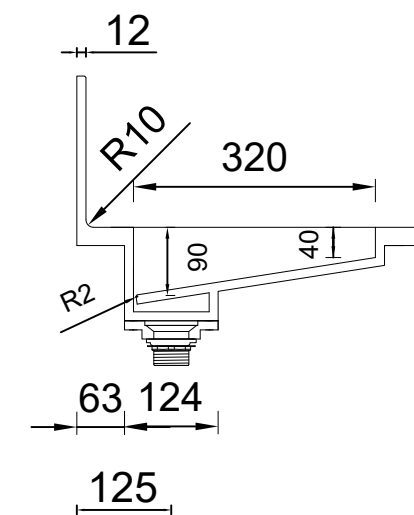
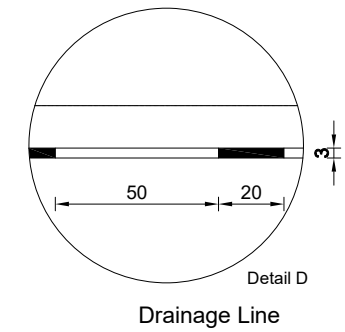
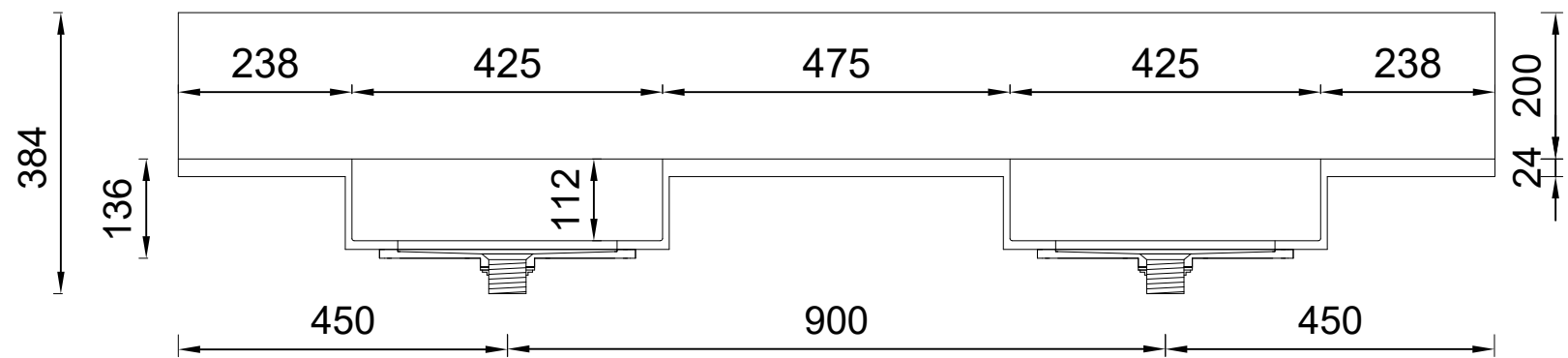
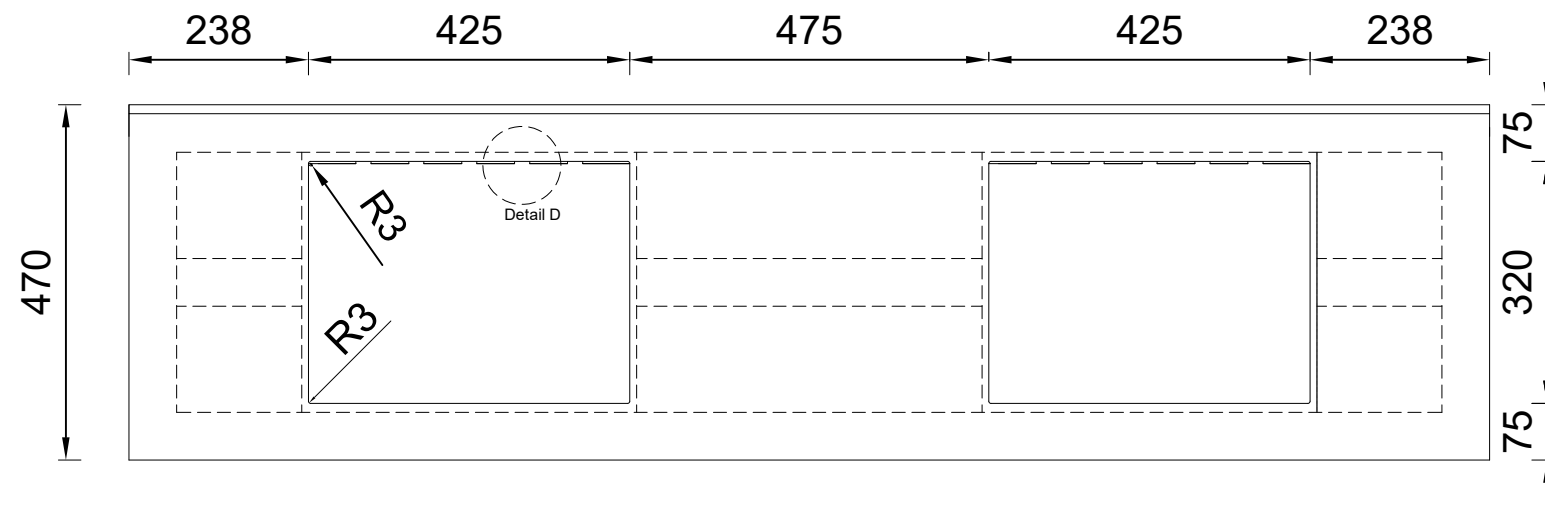

CASF Australia  
 Unit 3, 208 Walters Road, Arndell Park NSW 2148  
 Tel: 1300 795 044  
 Email: projects@casf.com.au



3	2 waste fitting, pre-assembled to # 2
2	2 Corian waste kit, pre-assembled to #1
1	1 Corian Washplane 4222
#	Packing List