

Corian® Specification Sheet : 3224 Washplane

Notes:

Tap hole cutouts not included, drawing for location reference only.
 All exposed edges sanded to 2mm radius.
 All exposed surface sanded to semi-gloss finish.
 Net weight: 98 Kgs

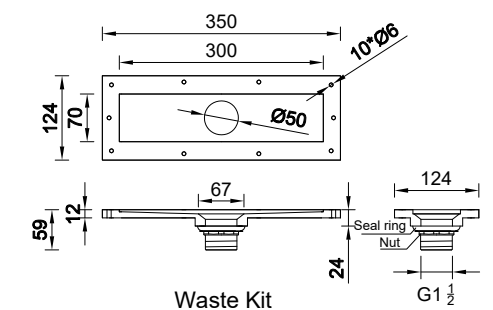
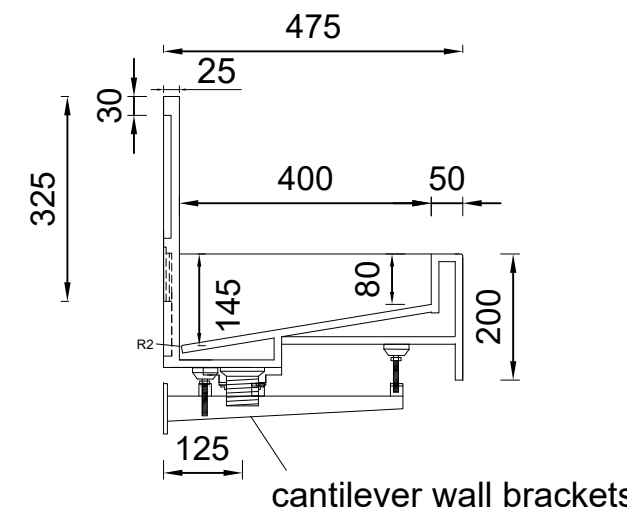
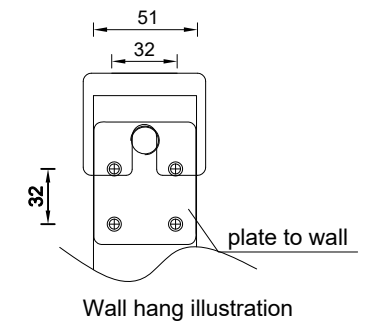
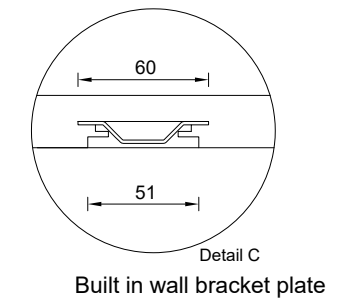
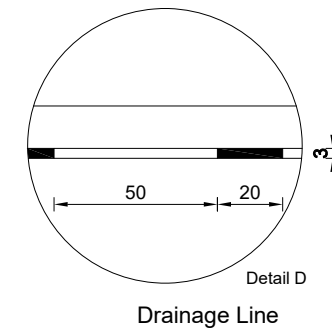
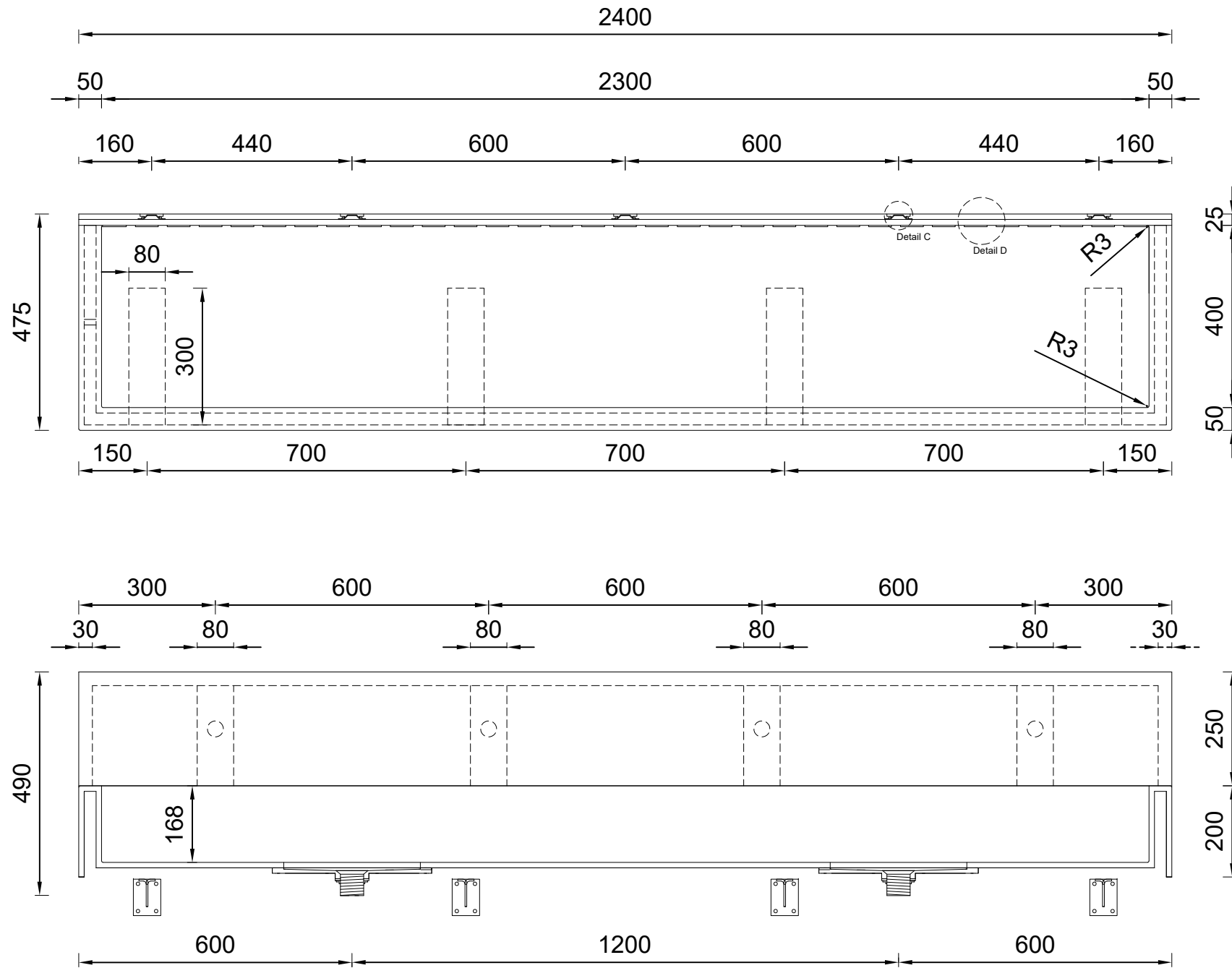

6	1 plywood wall bracket hanging holes template
5	5 wall bracket fixing plates & screws
4	4 380mm adjustable cantilever wall brackets & screws
3	2 waste fitting, pre-assembled to # 2
2	2 Corian waste kit, pre-assembled to #1
1	1 Corian Washplane 3224
#	Packing List