

Corian® Specification Sheet : 3223 Washplane

Notes:

Tap hole cutouts not included, drawing for location reference only.
 All exposed edges sanded to 2mm radius.
 All exposed surface sanded to semi-gloss finish.
 Net weight: 75 Kgs

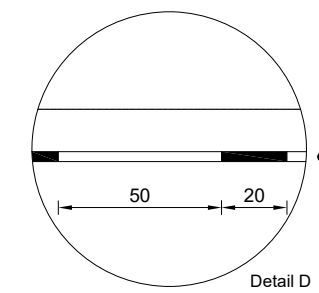
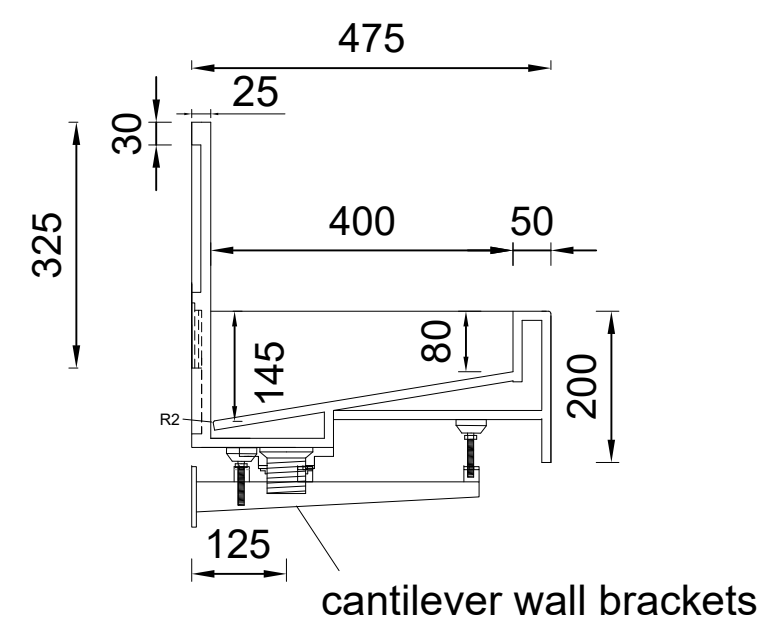
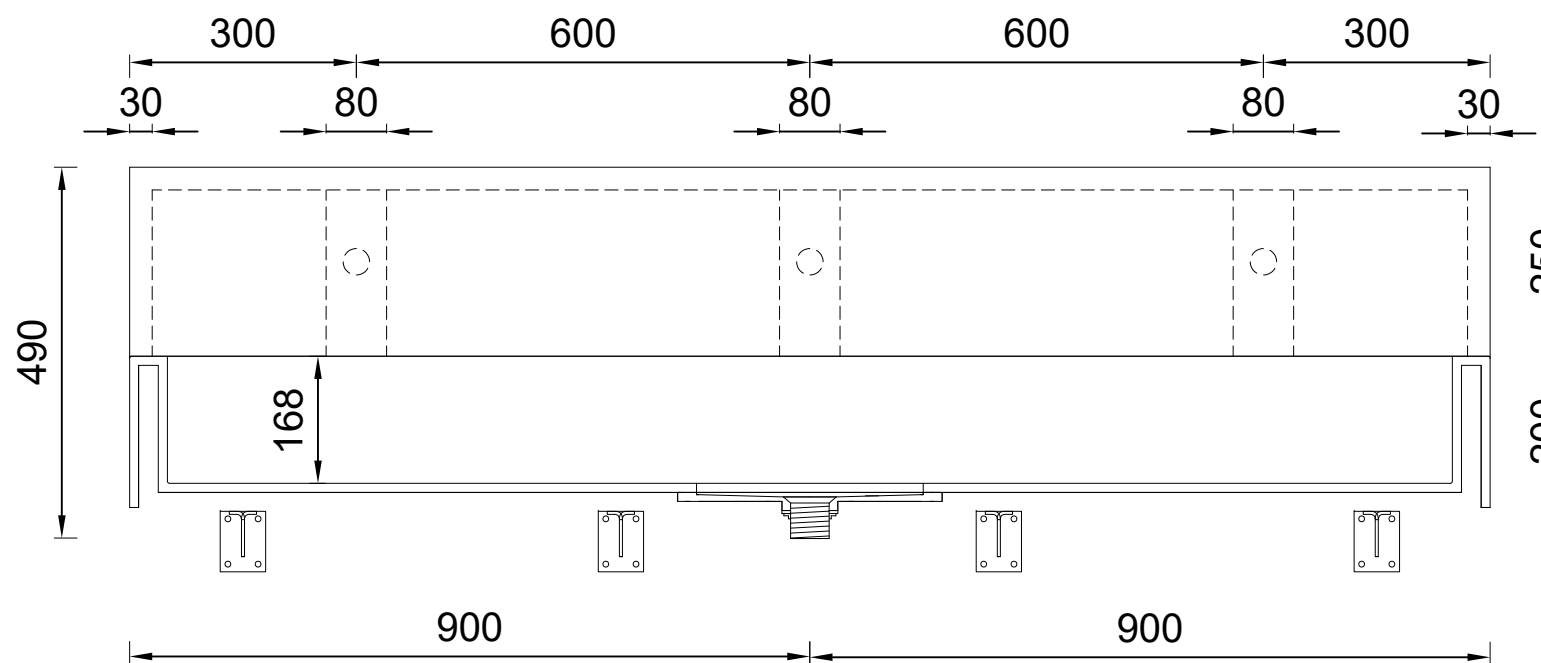
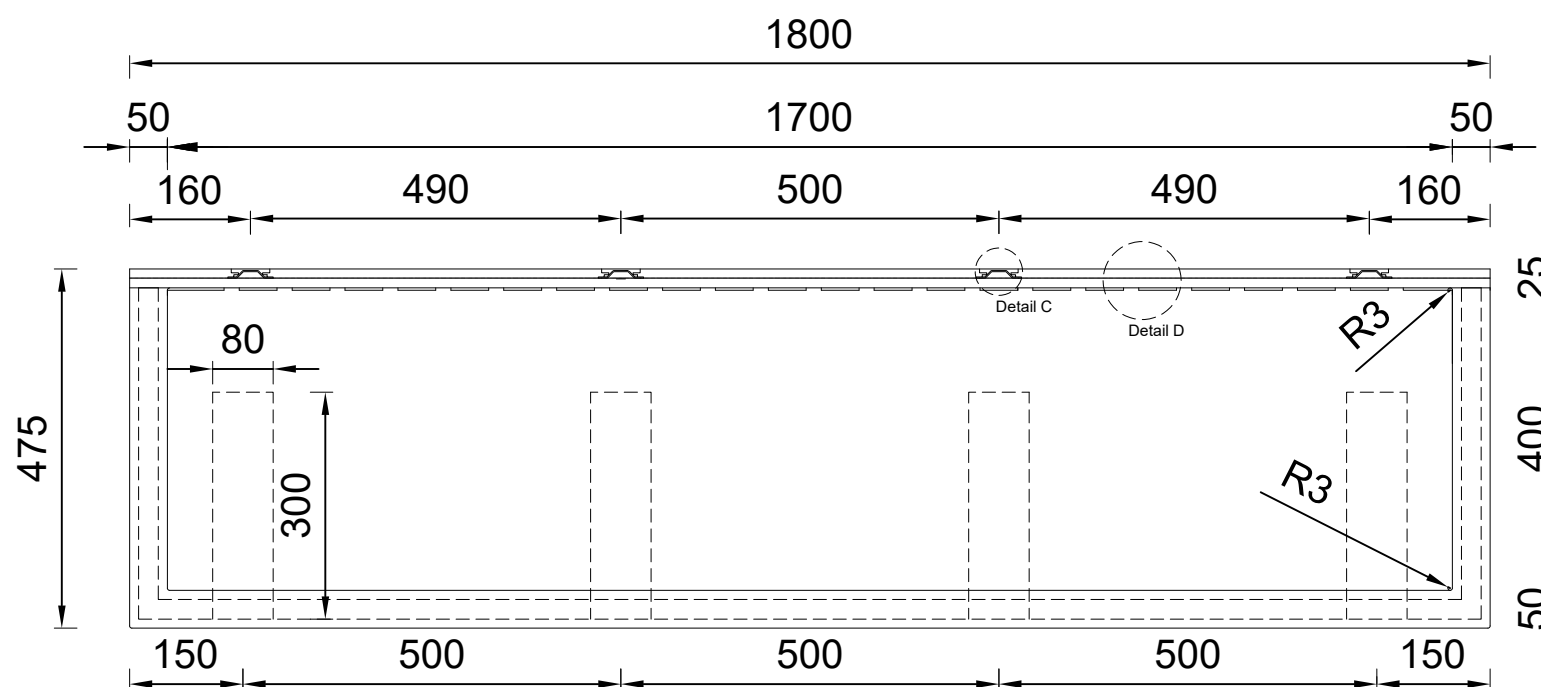

Drainage Line

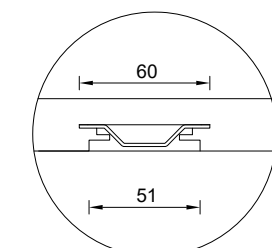

Built in wall bracket plate

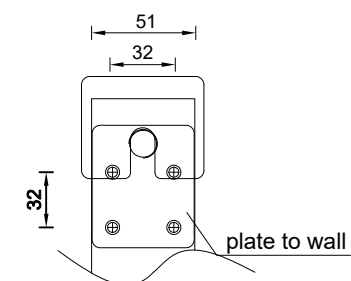

Wall hang illustration

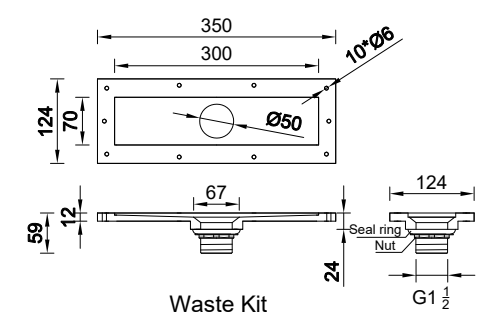

Waste Kit

6	1 plywood wall bracket hanging holes template
5	4 wall bracket fixing plates & screws
4	4 380mm adjustable cantilever wall brackets & screws
3	1 waste fitting, pre-assembled to # 2
2	1 Corian waste kit, pre-assembled to #1
1	1 Corian Washplane 3223
#	Packing List

CASF Australia
 Unit 3, 208 Walters Road, Arndell Park NSW 2148
 Tel: 1300 795 044
 Email: projects@casf.com.au

