

Corian® Specification Sheet : 3145 Washplane

Notes:

Tap hole cutouts not included, drawing for location reference only.

All exposed edges sanded to 2mm radius.

All exposed surface sanded to semi-gloss finish.

Net weight: 85 Kgs

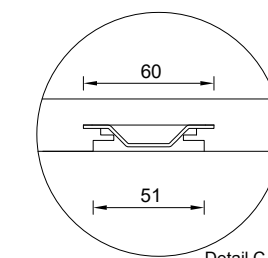
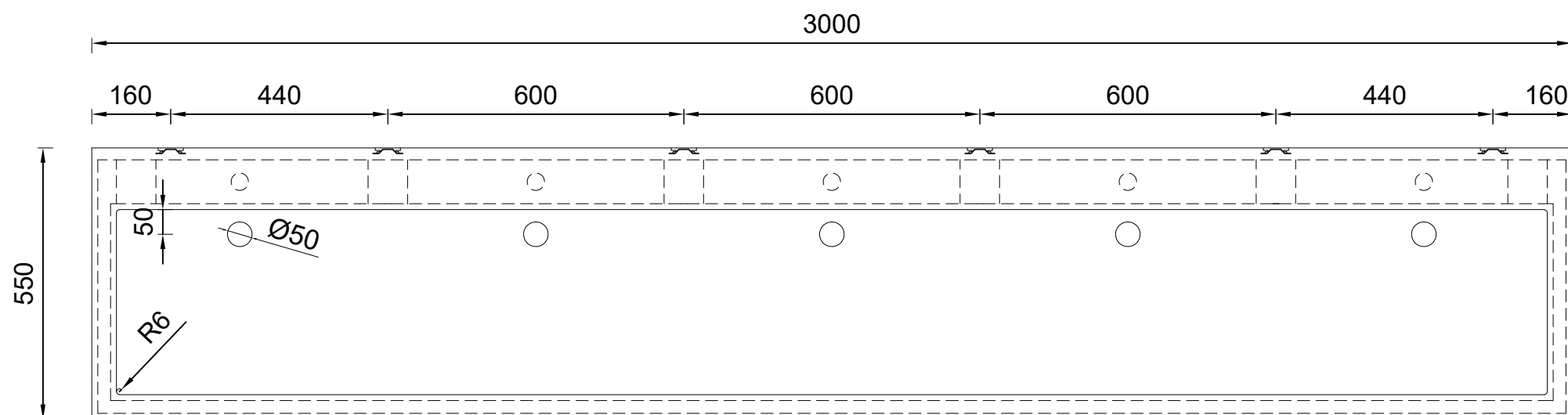

Detail C
Built in wall bracket plate

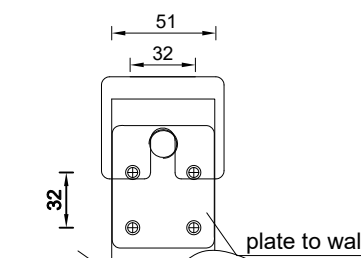

Wall hang illustration

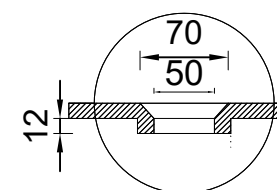
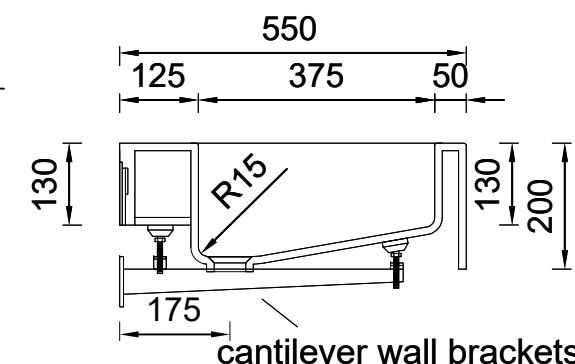
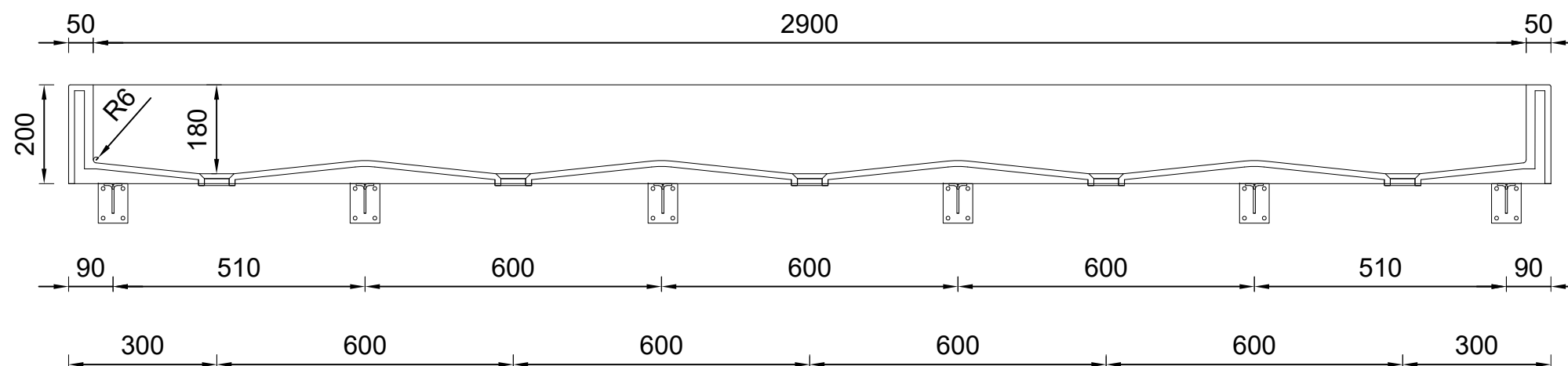

cantilever wall brackets

CASF Australia
Unit 3, 208 Walters Road, Arndell Park NSW 2148
Tel: 1300 795 044
Email: projects@casf.com.au



5	1 plywood wall bracket hanging holes template
4	6 wall bracket fixing plates & screws
3	6 450mm adjustable cantilever wall brackets & screws
2	5 waste fittings
1	1 Corian Washplane 3145
#	Packing List