

Corian® Specification Sheet : 3144 Washplane

Notes:

Tap hole cutouts not included, drawing for location reference only.

All exposed edges sanded to 2mm radius.

All exposed surface sanded to semi-gloss finish.

Net weight: 70 Kgs

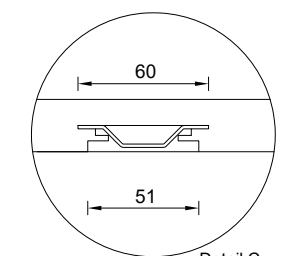
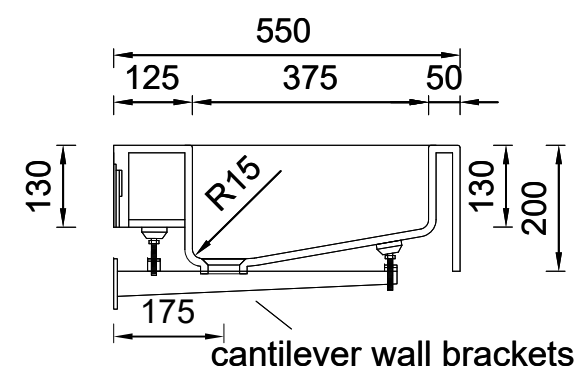
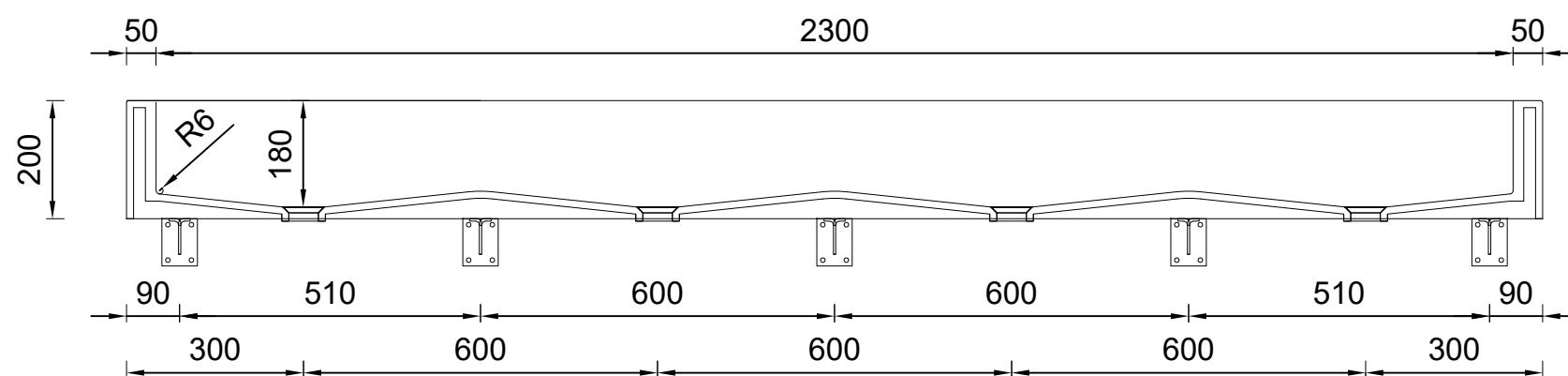
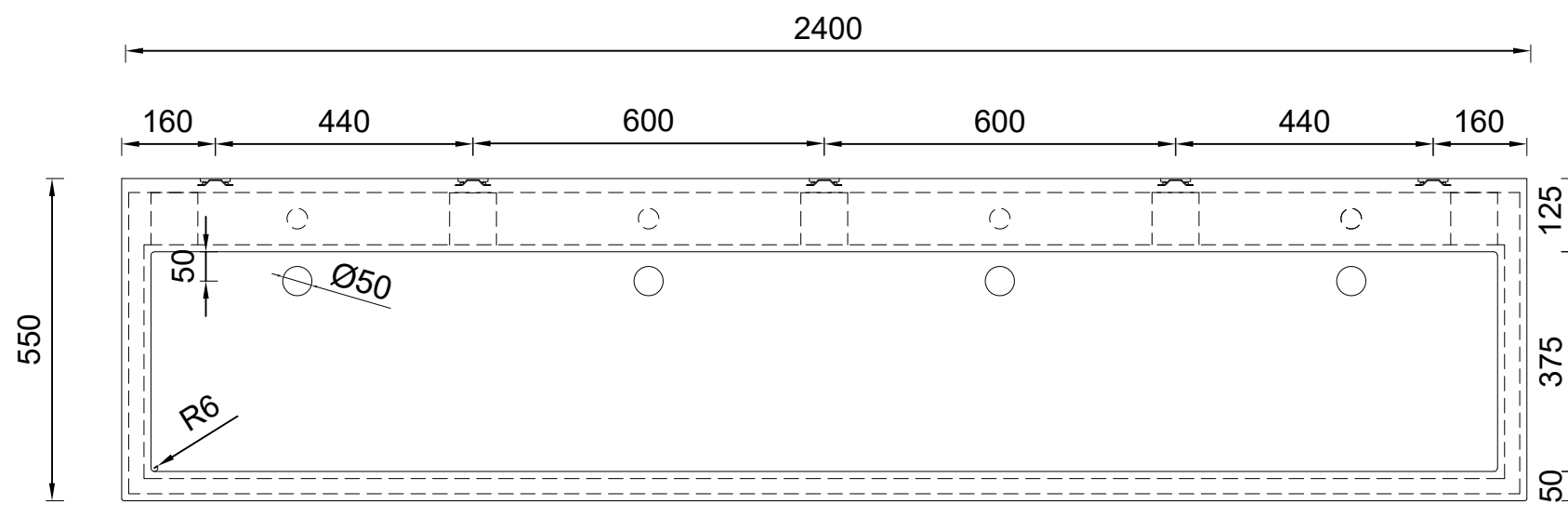

Detail C
Built in wall bracket plate

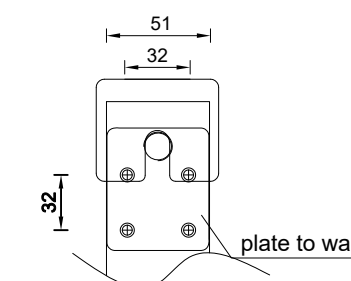

Wall hang illustration

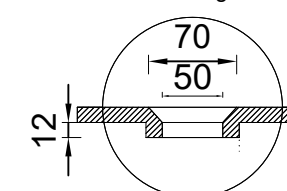

CASF Australia
Unit 3, 208 Walters Road, Arndell Park NSW 2148
Tel: 1300 795 044
Email: projects@casf.com.au



5	1 plywood wall bracket hanging holes template
4	5 wall bracket fixing plates & screws
3	5 450mm adjustable cantilever wall brackets & screws
2	4 waste fittings
1	1 Corian Washplane 3144
#	Packing List