

# Corian® Specification Sheet : 3142 Washplane

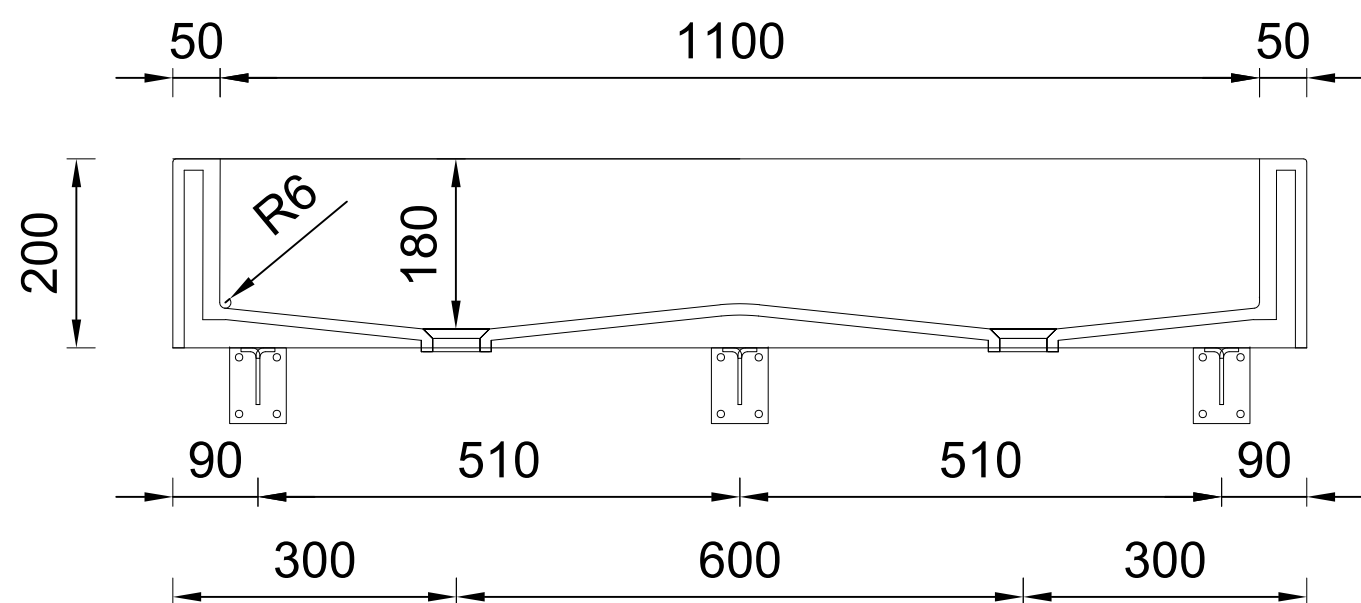

## Notes:

Tap hole cutouts not included, drawing for location reference only.  
 All exposed edges sanded to 2mm radius.  
 All exposed surface sanded to semi-gloss finish.  
 Net weight: 39 Kgs

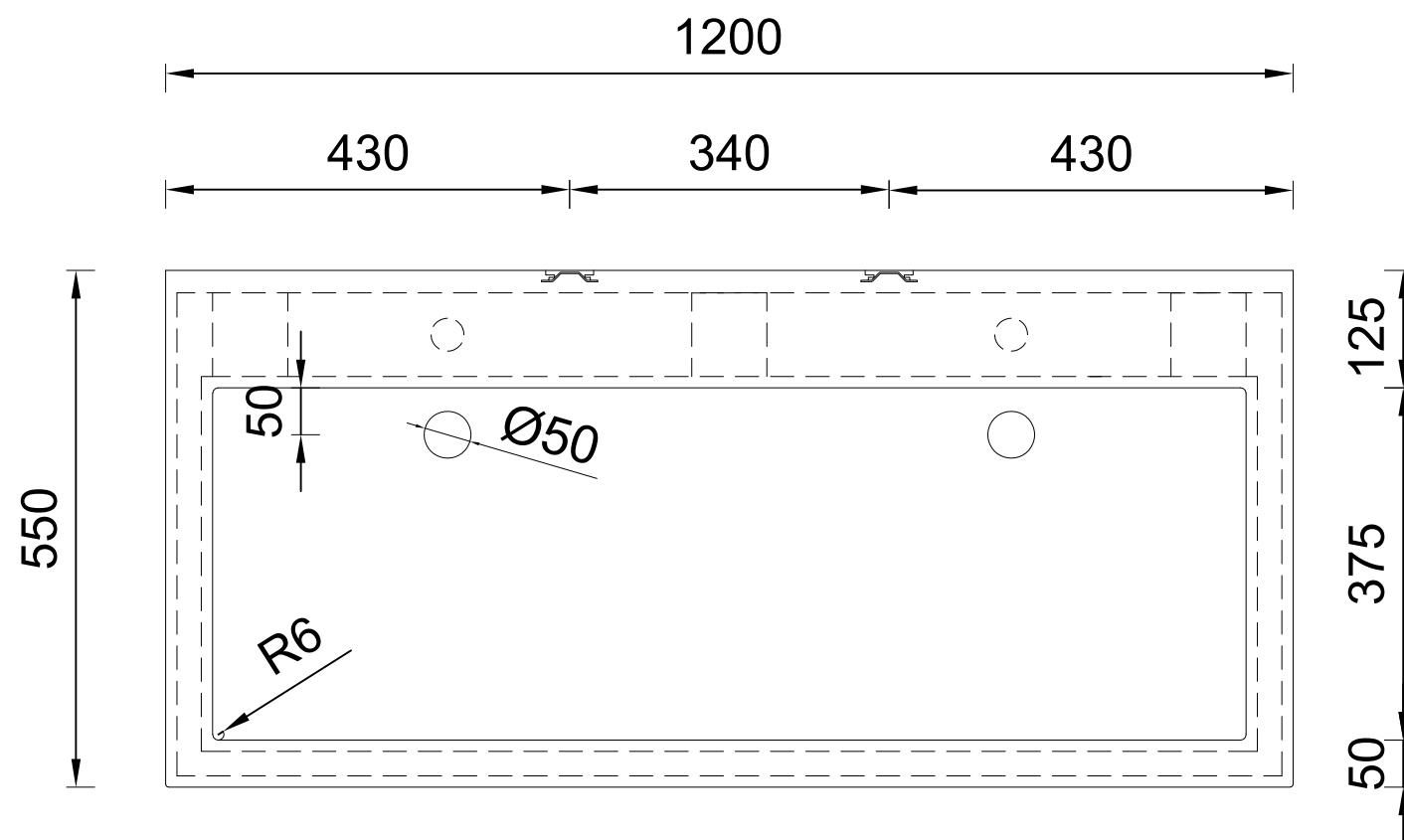
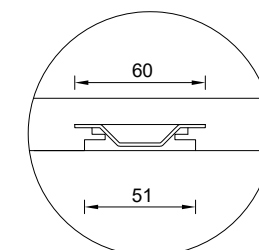

Detail C  
Built in wall bracket plate

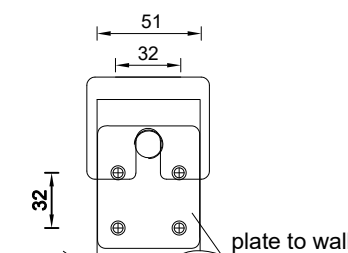

Wall hang illustration

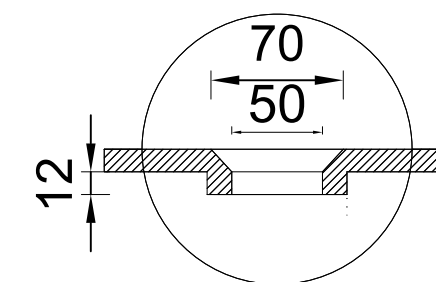
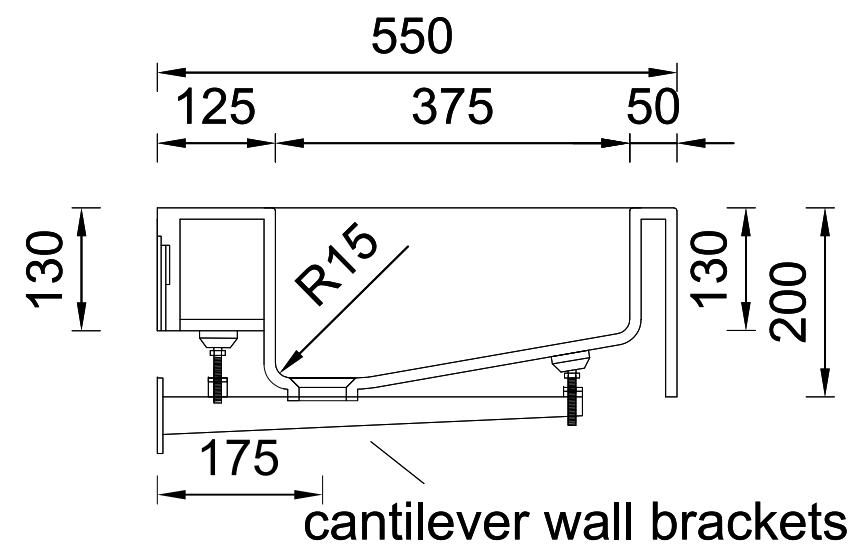

CASF Australia  
 Unit 3, 208 Walters Road, Arndell Park NSW 2148  
 Tel: 1300 795 044  
 Email: projects@casf.com.au



5	1 plywood wall bracket hanging holes template
4	2 wall bracket fixing plates & screws
3	3 450mm adjustable cantilever wall brackets & screws
2	2 waste fittings
1	1 Corian Washplane 3142
#	Packing List