

Corian® Specification Sheet : PWD Washplane 5211L 720

Notes:

Tap hole cutouts not included, drawing for location reference only.
All exposed edges sanded to 2mm radius.
All exposed surface sanded to semi-gloss finish.
Net weight: 21 Kgs

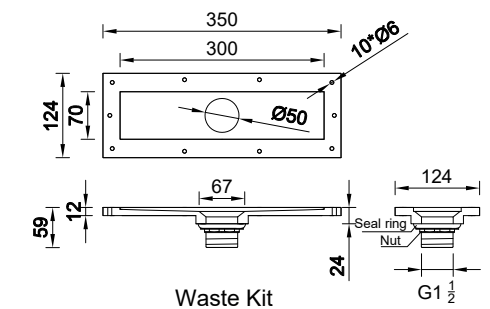
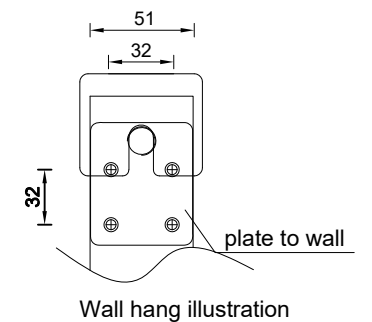
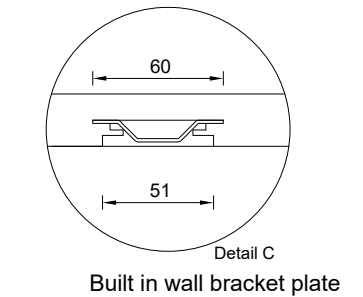
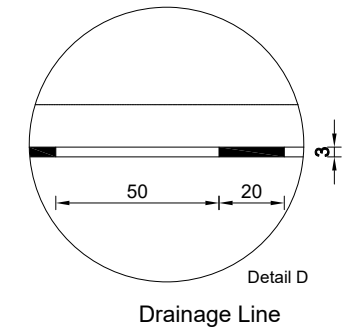
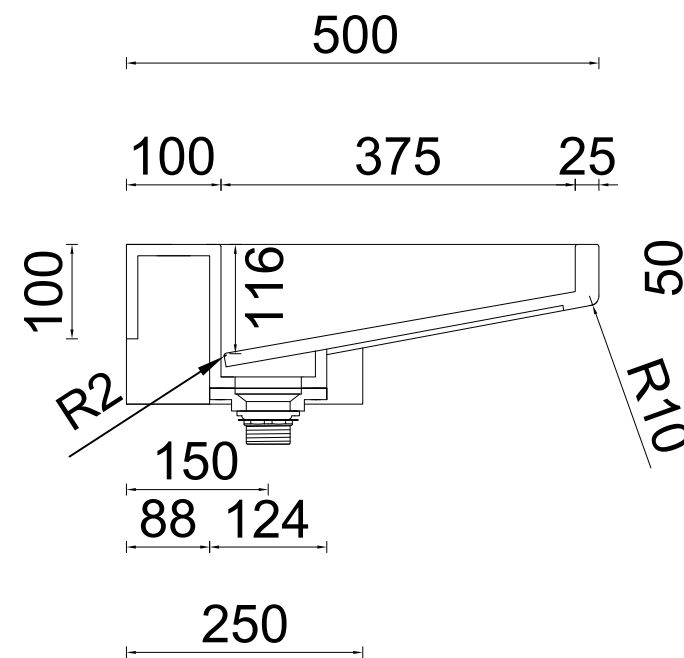
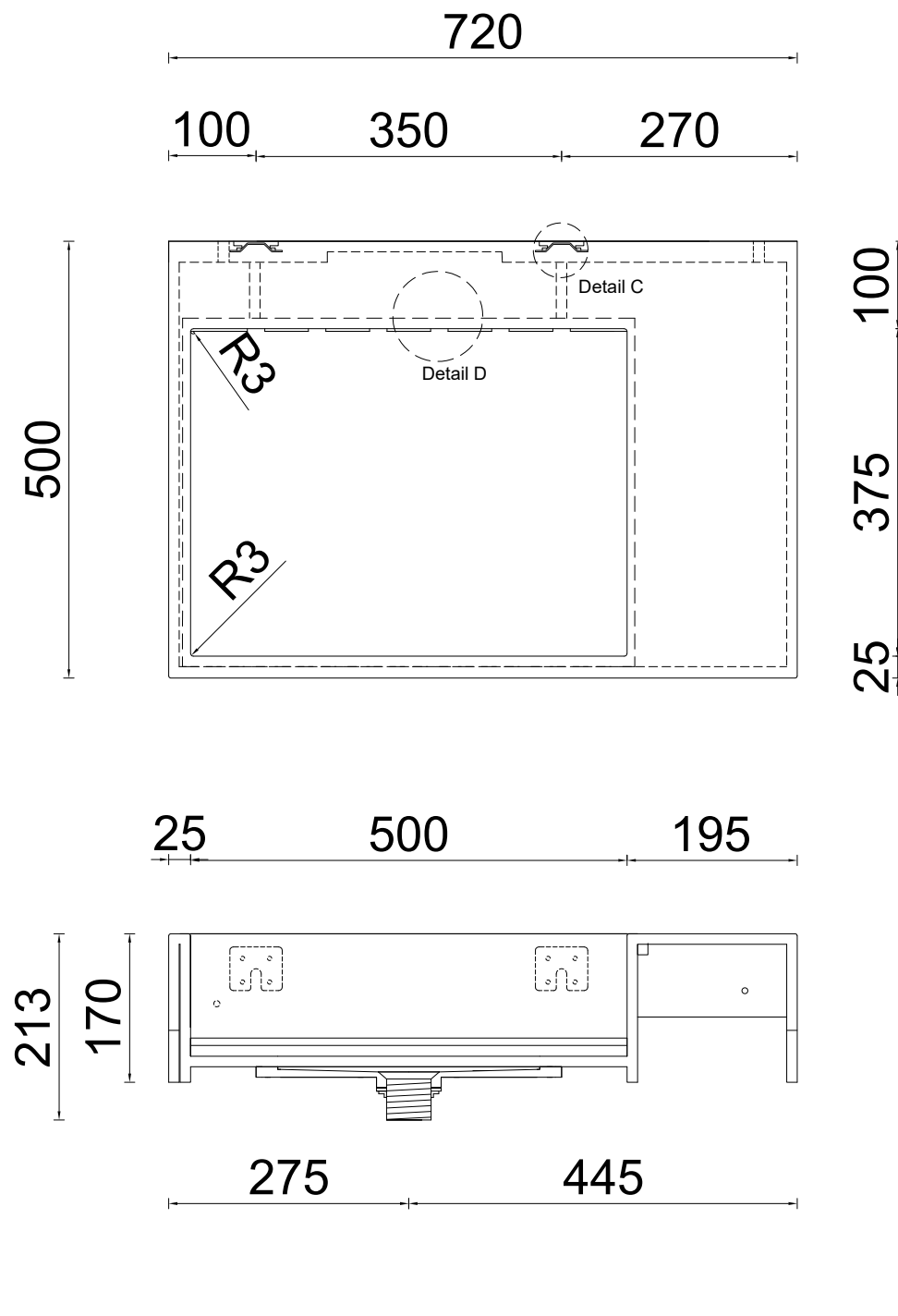

CASF Australia
Unit 3, 208 Walters Road, Arndell Park NSW 2148
Tel: 1300 795 044
Email: projects@casf.com.au



6	1 plywood wall bracket hanging holes template
5	2 wall bracket fixing plates & screws
4	2 M8X80 expansion bolt
3	1 waste fitting, pre-assembled to # 2
2	1 Corian waste kit, pre-assembled to #1
1	1 Corian Washplane PWD 5211L 720mm
#	Packing List