

Corian® Specification Sheet : 6223 Washplane

[Revised September 2022]

Notes:

Tap hole cutouts not included, drawing for location reference only.
 All external edges sanded to 2mm radius
 Top surface sanded to semi-gloss finish

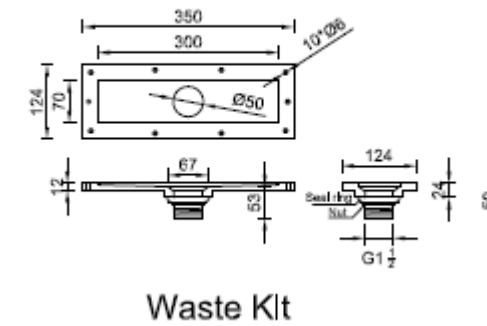
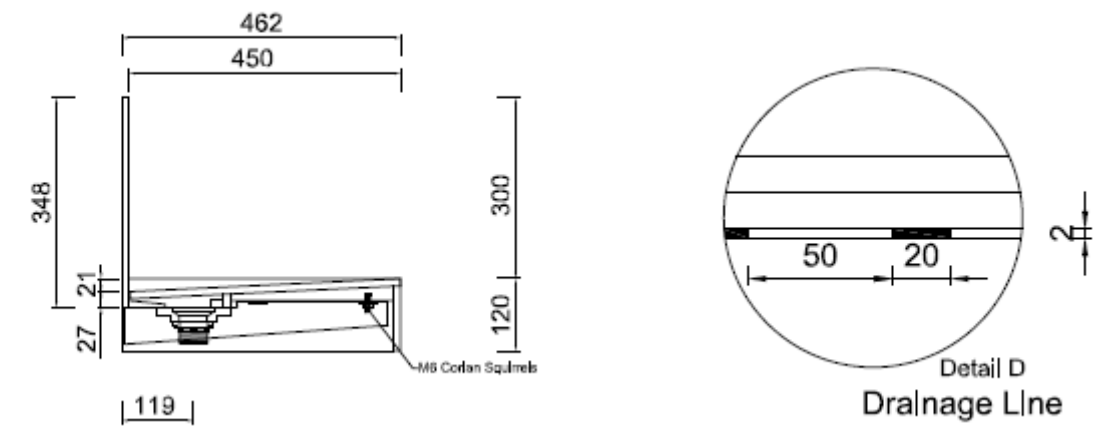
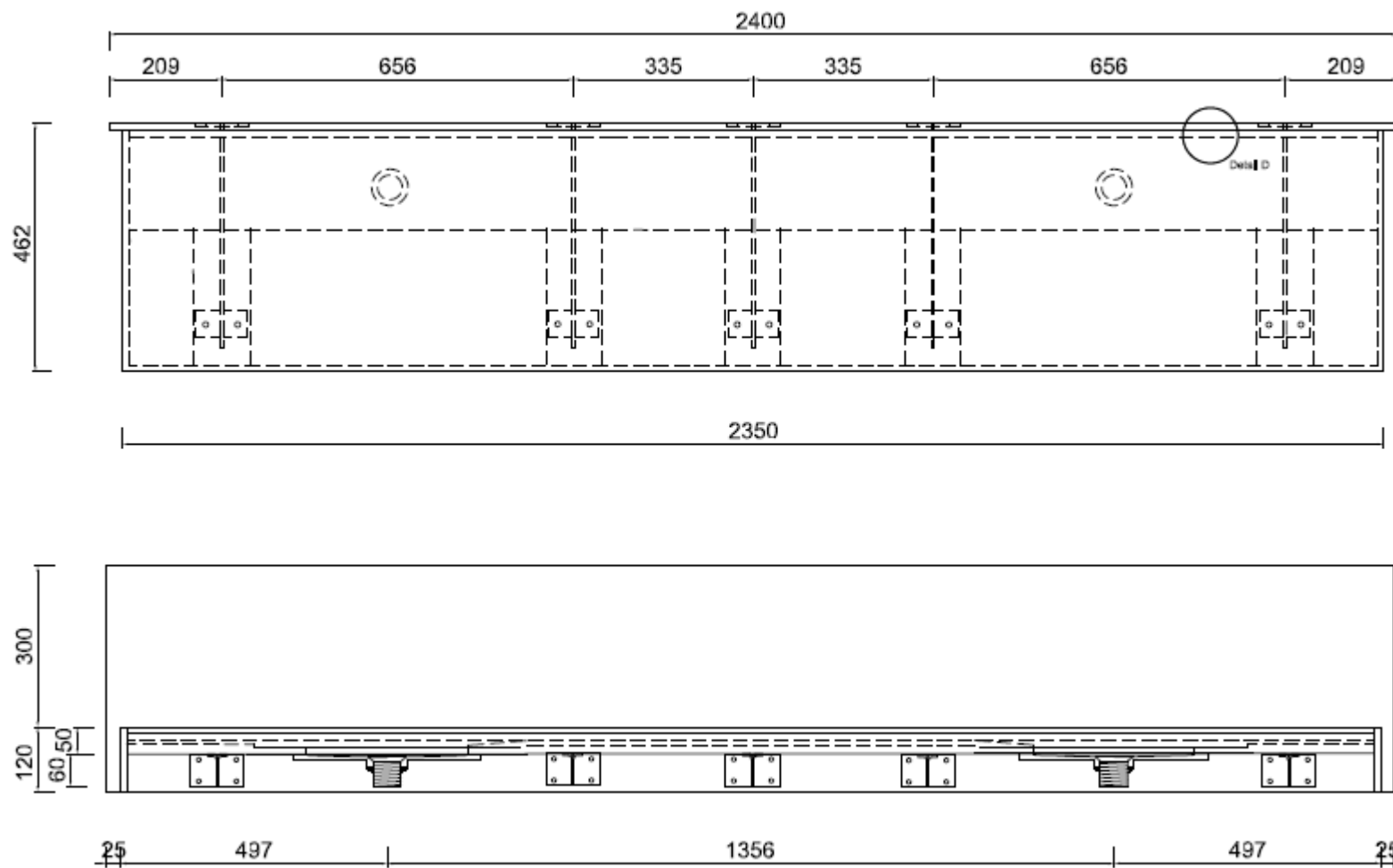

CASF Australia
 Unit 3, 208 Walters Road, Arndell Park NSW 2148
 Tel: 1300 795 044
 Email: projects@casf.com.au

casf
 your space your way

CORIAN®
 SOLID SURFACE

4	5 x slimline cantilever wall brackets and screws
3	2 waste fittings, pre-assembled to #2
2	2 Corian waste kits, pre-assembled to #1
1	1 Corian Washplane
#	Packing List