

# Corian® Specification Sheet : 6222 Washplane

[Revised September 2022]

## Notes:

- Tap hole cutouts not included, drawing for location reference only.
- All external edges sanded to 2mm radius
- Top surface sanded to semi-gloss finish

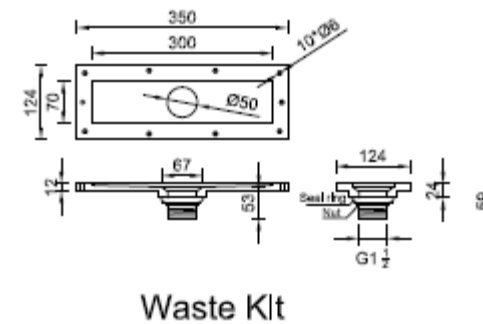
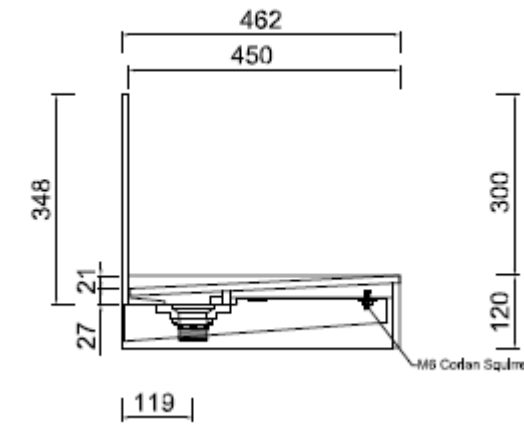
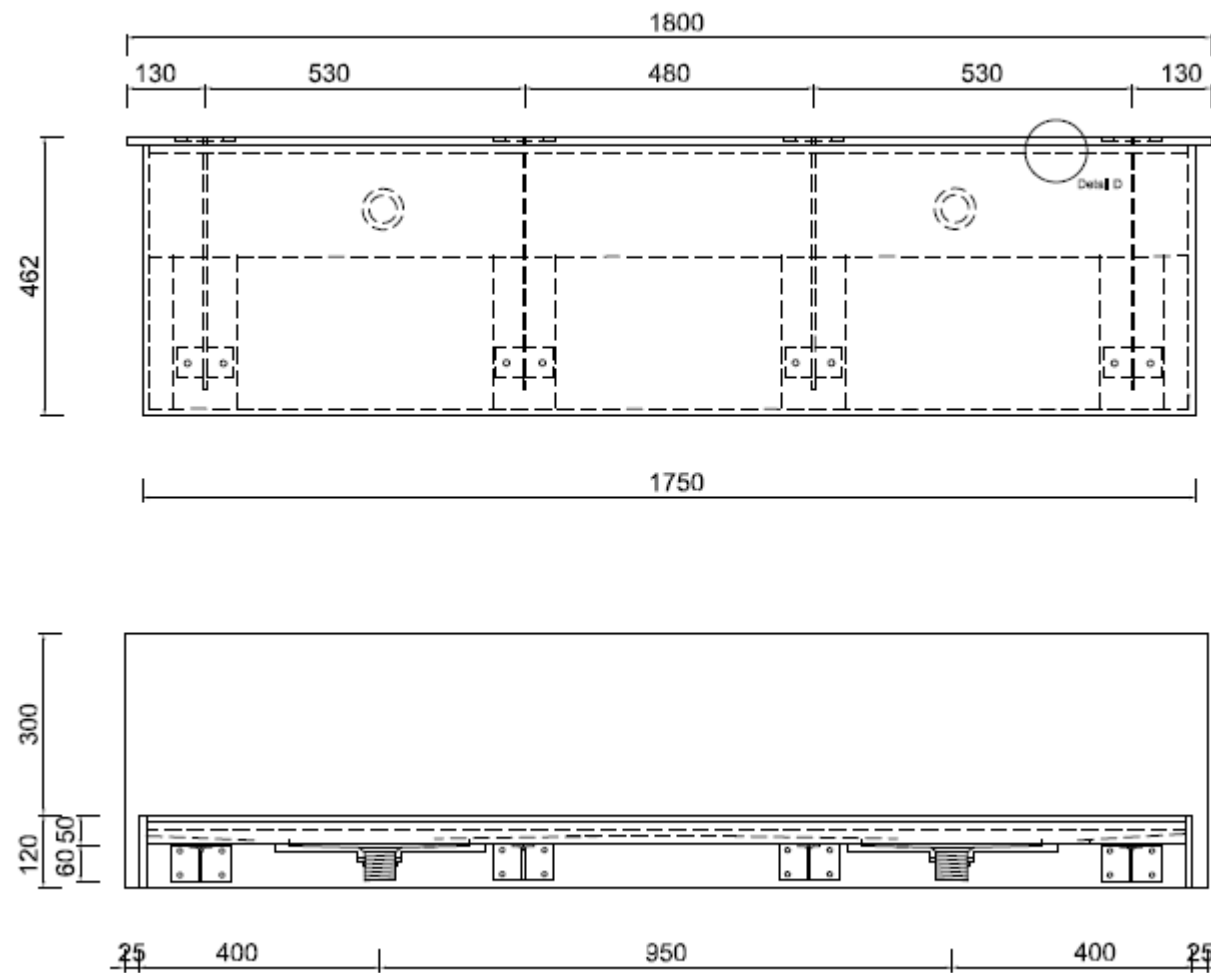

CASF Australia  
 Unit 3, 208 Walters Road, Arndell Park NSW 2148  
 Tel: 1300 795 044  
 Email: projects@casf.com.au



4	4 x slimline cantilever wall brackets and screws
3	2 waste fittings, pre-assembled to #2
2	2 Corian waste kits, pre-assembled to #1
1	1 Corian Washplane
#	Packing List