

MICA AESTHETICS

INTRODUCTION

This bulletin summarizes the procedures for fabricating DuPont™ Corian® solid surface containing mica flakes. All typical fabrication and installation requirements, seam reinforcement, for example, must be followed.

OVERVIEW

Corian® solid surface products with reflective mica flake exhibit slight to moderate directionality. The degree of directionality varies with mica sizes and concentrations. Directionality is more apparent with smaller flakes at higher concentrations where the mica flakes contribute to the “background” appearance.

For best visual results, you will need to consider directionality of the sheet, lighting type and locations from where observers will view the sheet, the impact on layout, and assembly techniques. This bulletin contains several design ideas to get you started. With experience, you will likely find additional techniques to maximize the beauty and visual activity of your installations. Be sure to show samples to your customer to ensure that the design will meet their expectations.

Refer to the *DuPont™ Corian® Solid Surface Product Fabrication Bulletin – Directional Aesthetics* (K-26833) for a listing of colors that have some degree of directionality and the appropriate Product Fabrication Bulletin to follow.

The fabrication methods shown here often require more sheet and fabrication effort than standard colors. It is important to bid based on the sheet and effort required, not on a square foot basis. The time to discuss the various fabrication methods, their effects on cost and appearance, and to set expectations is BEFORE fabrication so the customer is not surprised by the results. Physical samples can be helpful when setting expectations.

This bulletin focuses on the unique characteristics of these colors. The focus is on fabrication techniques that are unique to these colors and assume an understanding

of Corian® fabrication. All typical fabrication and installation requirements, seam reinforcement, for example, must be followed. For complete details of assembly procedures, refer to the *DuPont™ Corian® Solid Surface Fabrication/Installation Fundamentals* bulletins. Illustrations shown here are not completely representative of proper fabrication procedure. All inside corners must be radiused. Reference *DuPont™ Corian® Solid Surface Fabrication/Installation Fundamentals – Requirements* (K-25705) for further details.

A. KEY DESIGN POINTS

This product is directional, both on the top surface and on the edges. While changes in reflectivity at seams may be minimized with the techniques shown here, it is generally not possible to eliminate the visibility from all angles of observation.

The reflectivity of sheet edges significantly less than the face of the sheet. If a uniform edge profile is required, a v-groove edge is recommended.

The directional nature of the sheet must be accounted for during design and fabrication. This directionality persists through the thickness and is most apparent along the length of the sheet. If two sections are joined with different orientations so that they look different on the top surface, the edge profiles may also look different.

Using the orientation of the product back side labeling as a reference direction and marking all cut pieces with a directional arrow will help later with properly orienting the pieces during assembly. Otherwise, it may be difficult to visually determine orientation of the cut pieces until they are seamed together and the sample is finished.

All references to orientation in this bulletin will be relative to the backside label on the sheet. When the sheet is oriented so the text is upright, 0° will be **LEFT**, 90° will be **UP**, 180° will be **RIGHT** and 270° will be **DOWN**. This terminology will also be used to describe viewing angles. For an uncut sheet, to view the 0° appearance is to stand at the 180° position and look towards 0°. This is similar to how you would read a compass, looking across the compass to look North.

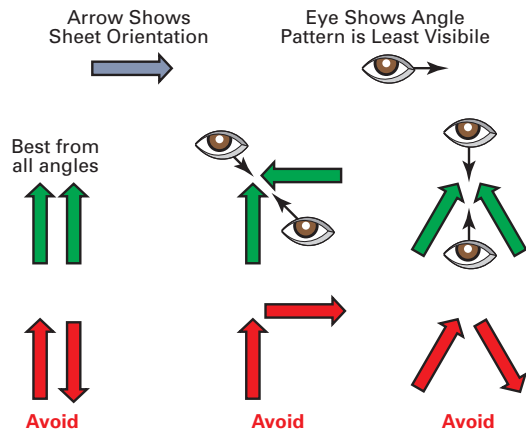

Figure E-1 - Designing to Minimize Directional Effects

Note that even two sheets seamed together with the same orientation may have a visible change in reflectivity at the seam when observed from certain angles for colors with stronger directional effects. For widths of less than two sheets, visibility will be minimized by removing equal amounts from each sheet along the inside of each sheet. The seam will then be made at the freshly cut edges.

F. SEAMS

Light reflection varies as the mica colors are viewed from different angles. This can appear as a color difference when sheets are joined. Common examples of where sheets may come together at 90° angles are “L” or “U” shaped tops. This is a natural feature of the aesthetic and will be more evident in some colors and finishes than others. It is best to have samples to show the customer so it is understood what the final piece will look like.

F.1. Diagonally Seamed Corners

When two sheets need to be joined at an angle a diagonal seam will provide the best appearance. A diagonal seam will provide a subtle, neatly tailored change in directionality. This seam will be least noticeable looking down the diagonal and directly above. The seam is most visible looking down the length of the sheets at low angles.

The sheet orientations should be as shown in the “correct” example in Figure F-1, backside sheet labels both pointing either towards the corner as in the diagram or both arrows pointing away from the corner. They should not meet in a head-to-tail orientation as shown in the “incorrect” example in F-1.

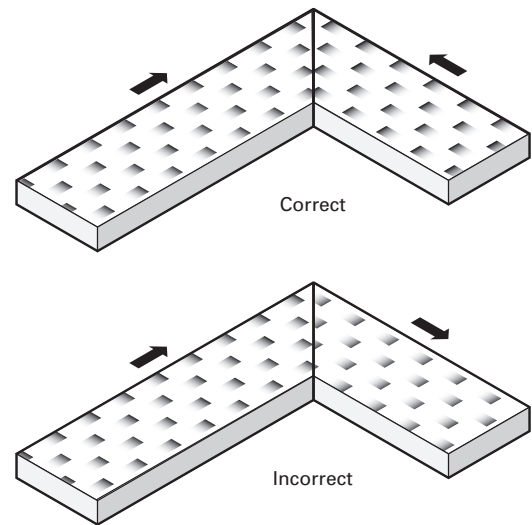

Figure F-1 - Diagonal Corner Seams

F.2. Offset-Seamed Corners

If one side of an “L” is less than 60 inches (152.4 cm) then a typical off set seam can be used at the corner. Additional 30 inch sections could be added, maintaining the common orientation as shown in Figure F-2.

The sheet orientations should be as below on the left, with the arrows in the backside label both pointing in the same direction.

See DuPont™ Corian® Fabrication/Installation Fundamentals – Positioning of Seams (K-25288) for more information.

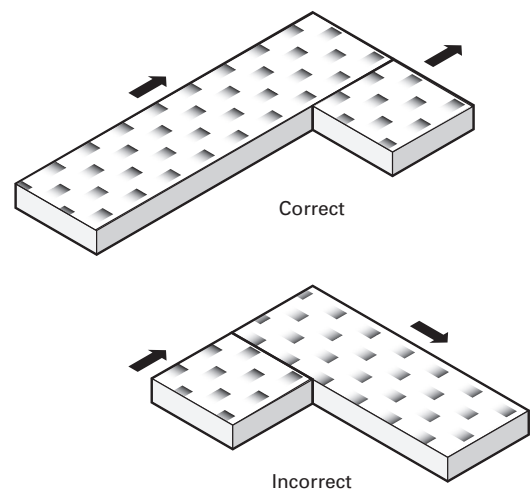

Figure F-2 - Offset Corner Seams

MICA AESTHETICS

G. EDGE OR CORNER DETAILS

This section addresses options for corners or edges. The mica aesthetic colors have reflective mica flakes that are generally oriented in the plane of the sheet. Thus the edge of the sheet shows the edges of the mica flakes. As the edges reflect less light compared to the surface of the flake, the edges of the sheet will have a darker, less reflective appearance.

If a drop edge is used, the surface reflectivity of the vertical edge contrasts with the edge view of the top sheet.

Therefore a more suitable aesthetic is obtained using a v-groove edge. A v-groove edge will give the most uniform appearance when a tight radius is used. A small radius may be used, but lack of reflectivity in the radius may be noticeable above a $\frac{3}{16}$ " (5 mm) radius.

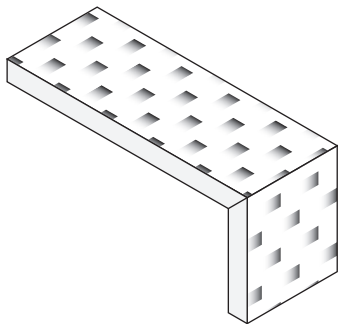

Figure G-1 - V-groove Edge

The appearance of a stacked edge does differ from the top appearance and there will be relatively little reflectivity on the edge. This is most apparent for a flat edge. The stacked sheets should have the same orientation as the top sheet. Different profiles (bullnose, ogee, etc.) will give different effects.

Drop edges or a butt seam on a vertical corner are not recommended unless the visual contrast is desired. In all cases, having samples to show customers so they understand the visual details will help avoid surprises when the job is installed. An ogee or a bevel may create an acceptable edge, though reflectivity will be lower and vary with angle of observation. The ogee or bevel cut should extend to the seam with the drop edge. This is deeper than typical and will necessitate reinforcing the drop edge with another strip of sheet (double thickness).

See *DuPont™ Corian® Fabrication/Installation Fundamentals – Edge Details and Buildups* (K-25293) for more information.

H. COVES

For aesthetics with mica reflectivity varies with the orientation of the mica flakes to the viewer. Creating the cove reveals the interior of the sheet, and the mica flakes will not be aligned with the surface cut of the cove. Depending on the angle of observation, the cove may match, but will tend to look darker than the horizontal or vertical surfaces surrounding it at other angles. Coves are therefore not recommended if the aesthetic has significant reflectivity. If a cove is required, the v-groove technique provides the best cove, but it will be visible from some angles. Make sure the customer sees a sample and approves the appearance. Set-on or butt-seamed back splashes are recommended. See *DuPont™ Corian® Fabrication/Installation Fundamentals – Backsplashes* (K-25294) for more information.

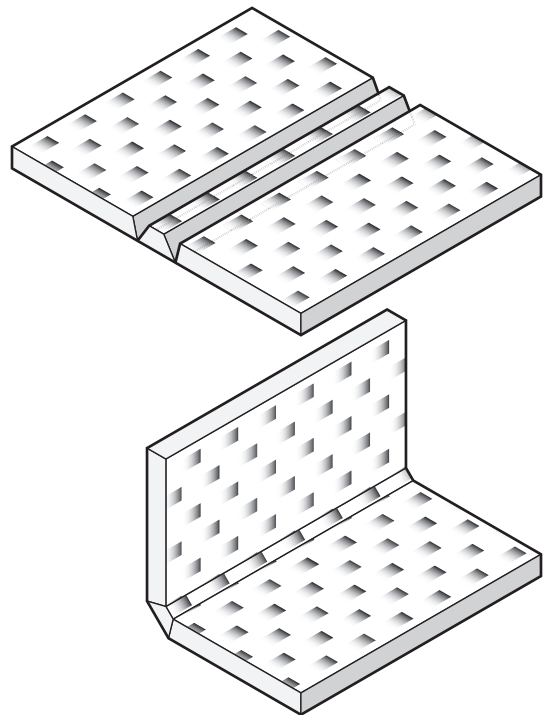

Figure H-1 - V-groove Cove

I. THERMOFORMING

DuPont™ Corian® solid surface with mica flake can be thermoformed using typical settings. Thermoforming behavior will be comparable to products similar in coloration without mica flake. It is important to account for directionality during the design of the part and during fabrication. To track orientation it is best to put arrows on each piece indicating the orientation relative to the backside label. See *DuPont™ Corian® Fabrication/Installation Fundamentals – Thermoforming* (K-25297) for more information.

MICA AESTHETICS

J. FINISHING

All typical finishing methods are suitable to use on Corian® colors containing mica. Darker colors may have a better appearance with a semi-gloss finish. As with other dark colors, the color will get darker and deeper with higher gloss finishes. The mica flakes and directionality effects will also be more apparent at higher glosses. The consumer should be made aware of the proper care and maintenance instructions for the provided gloss level. The use of low angle lighting will help highlight scratches for removal. It also may be necessary to finish up with a finer than normal grit of abrasive. As always, cleaning the top between grit changes is needed. The entire surface should have a uniform finish, paying particular attention to finishing after field seaming. See *DuPont™ Corian® Fabrication/Installation Fundamentals – Finishing and Polishing* (K-25298) for more information. For dark colors *DuPont™ Corian® Solid Surface Product Fabrication Bulletin – Fabricating Dark Colors* (K-27414) may also be useful.

K. COLOR SPECIFIC COMMENTS

The strength of the directional effect depends on the size, concentration and visibility of the mica. For products with fairly strong mica aesthetic effects (e.g. Anthracite) the directionality is most apparent at seams with changes in sheet orientation, coves, stack edges and 90° butt seams (e.g. drop edge). For products with more subtle mica aesthetic effects (e.g. Deep Anthracite) the directionality less apparent and may not be noticeable at seams with changes in sheet orientation and coves. The lack of reflectivity on the edges of the sheet is still readily apparent for stack edges and 90° butt seams (e.g. drop edge). Physical samples are effective at demonstrating the effects and determining if the end result will be accepted by the customer.

L. SUMMARY

The directional nature of mica flakes in these Corian® colors allows for some creative designs that change with viewing angle. When directionality is not desired many typical fabrication techniques can be used, but an awareness of the impact of sheet orientation on fabrication methods is required to minimize the effect of directionality. In addition, all requirements as set forth in Tech Bulletin, *DuPont™ Corian® Solid Surface Fabrication/Installation Fundamentals Requirements* (K-25705) must be followed.

M. REFERENCED DOCUMENTS

DuPont™ Corian® Fabrication/Installation Fundamentals – Positioning of Seams (K-25288)
DuPont™ Corian® Fabrication/Installation Fundamentals – Edge Details and Buildups (K-25293)
DuPont™ Corian® Fabrication/Installation Fundamentals – Backsplashes (K-25294)
DuPont™ Corian® Fabrication/Installation Fundamentals – Thermoforming (K-25297)
DuPont™ Corian® Fabrication/Installation Fundamentals – Finishing and Polishing (K-25298)
DuPont™ Corian® Fabrication/Installation Fundamentals – Requirements (K-25705)
DuPont™ Corian® Solid Surface Product Fabrication Bulletin – Directional Aesthetics (K-26833)
DuPont™ Corian® Solid Surface Product Fabrication Bulletin – Fabricating Dark Colors (K-27414)

Disclaimer:

This information is based on technical data that E.I. du Pont de Nemours and Company and its affiliates ("DuPont") believe to be reliable, and is intended for use by persons having technical skill and at their own discretion and risk. DuPont cannot and does not warrant that this information is absolutely current or accurate, although every effort is made to ensure that it is kept as current and accurate as possible. Because conditions of use are outside DuPont's control, DuPont makes no representations or warranties, express or implied, with respect to the information, or any part thereof, including any warranties of title, non-infringement of copyright or patent rights of others, merchantability, or fitness or suitability for any purpose and assumes no liability or responsibility for the accuracy, completeness, or usefulness of any information. This information should not be relied upon to create specifications, designs, or installation guidelines. The persons responsible for the use and handling of the product are responsible for ensuring the design, fabrication, or installation methods and process present no health or safety hazards. Do not attempt to perform specification, design, fabrication, or installation work without proper training or without the proper personal protection equipment. Nothing herein is to be taken as a license to operate under or a recommendation to infringe any patents. DuPont shall have no liability for the use of or results obtained from such information, whether or not based on DuPont's negligence. DuPont shall not be liable for (i) any damages, including claims relating to the specification, design, fabrication, installation, or combination of this product with any other product(s), and (ii) special, direct, indirect or consequential damages. DuPont reserves the right to make changes to this information and to this disclaimer. DuPont encourages you to review this information and this disclaimer periodically for any updates or changes. Your continued access or use of this information shall be deemed your acceptance of this disclaimer and any changes and the reasonableness of these standards for notice of changes.

© E.I. du Pont de Nemours and Company 2013. All rights reserved.

The DuPont Oval, DuPont™ and Corian® are trademarks or registered trademarks of E.I. du Pont de Nemours and Company ("DuPont") or its affiliates. K-27484 12/13