

SINKS AND LAVATORIES

INTRODUCTION

This bulletin discusses installing DuPont™ Corian® solid surface sinks and lavatories.

OVERVIEW

High quality installations of DuPont™ Corian® solid surface sinks and lavatories are attractive and easy to clean. To properly install sinks, the correct tools and techniques are required. Two installation techniques are discussed, undermount installations with “soft” silicone seams and submount installations with “hard” joint adhesive seams.

A. TOOLS REQUIRED

The installation of Corian® solid surface sinks requires precise fabrication to ensure a proper installation. It is essential to use the correct tools. In addition, all tools must be kept in good condition and bits must be sharp.

There are two typical methods of mounting a sink. The preferred method for mounting DuPont™ Corian® solid surface sinks and lavatories is a “hard” seam submount where the edge of the deck and the sink are flush and the sink is attached to the deck with DuPont™ Joint Adhesive. An alternative mounting method for Corian® sinks and the preferred method for sinks made from alternative materials is the “soft” seam undermount method where the sink is often recessed from the edge of the deck and is adhered with silicone adhesive.

These items are essential for installing all sinks:

A.1. “Hard” seam submount

- strong, level workbench that can accommodate the shape when installed
- a 3-hp router with a 1" (25 mm) template guide and a 1/2" (13 mm) collet
- accurate template for the sink model being installed
- the recommended two router bits for doing seamed mounting:
 - 3/8" (10 mm) single-flute, carbide-tipped bit
 - combination bit

HELPFUL HINTS:

If making your own templates, use high-quality material and make sure they are manufactured to precise dimensions.

Do not use incorrect router bits.

A.2. “Soft” seam undermount

- strong, level workbench that can accommodate the shape when installed
- a 3-hp router with a 1" (25 mm) template guide and a 1/2" (13 mm) collet
- appropriate template for the sink model being installed

B. “HARD” SEAM SUBMOUNT INSTALLATION

In a submount installation the sink is hard seamed with DuPont™ Joint Adhesive to the underside of the countertop. The seam is then on the vertical plane of the sink, as illustrated in Figure B-1.

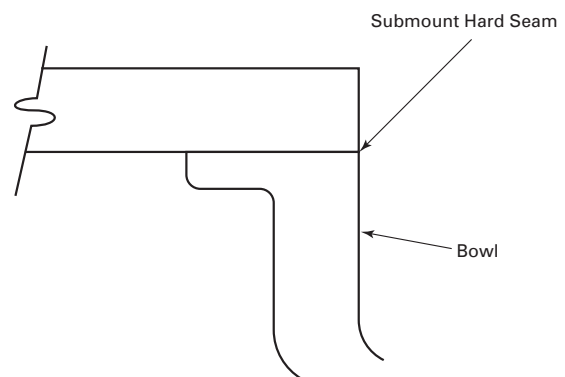

Figure B-1

Steps to completion:

1. Turn the sheet over and sand the area that the shape will be positioned on until smooth.
2. Clamp the template into position (sheet still upside-down).
3. Using a 3-hp router fitted with 1" (25 mm) template guide and 3/8" (10 mm) single-flute, carbide-tipped bit, rout the bowl cutout.
4. Remove the template and trial-fit bowl.
5. Adhere the bowl positioning blocks into position against bowl with hot-melt adhesive.
6. Inspect the rim face of the bowl for any imperfections.
7. Clean the face rim and the areas to be glued with clear, denatured alcohol¹.

¹Denatured alcohol is the preferred solvent for cleaning DuPont™ Corian® solid surface products. Acetone is approved for cleaning DuPont™ Corian® solid surface in regions where denatured alcohol is prohibited. Please see *DuPont™ Corian® Solid Surface Fabrication/Installation Fundamentals – Approved Cleaning Solvents* (K-25701) for more details.

SINKS AND LAVATORIES

8. Apply DuPont™ Joint Adhesive to the bowl flange as shown.
9. Turn bowl over and position against stop blocks. Check for proper alignment.

Joint Adhesive Pattern for Seamed Undermount Bowls

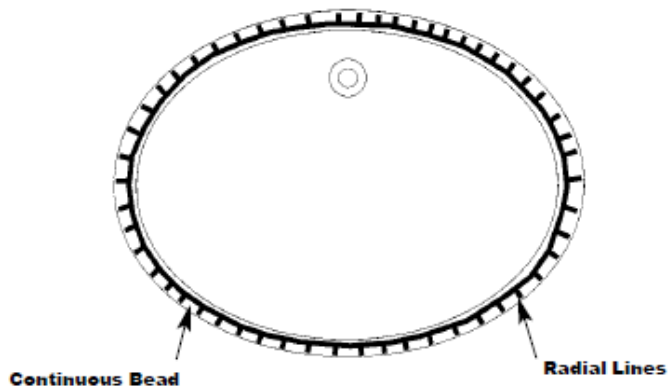

Figure B-2

10. Press bowl firmly in place. Look down through drain hole to check if there is squeeze-out around entire seam.

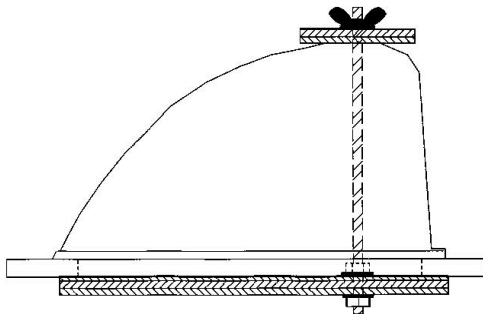

Figure B-3

11. Use bowl-clamping fixture (or similar device) to hold bowl until adhesive sets.
12. After adhesive sets, remove clamping fixture and turn bowl over.
13. Use a router equipped with a combination bit to rout excess sheet back to inside of bowl.
14. Sand and finish bowl and sheet in normal manner.

HELPFUL HINTS:

Do not forget to check that the bowl is properly seated into the adhesive and that it has a good, tight fit.

If router bit used to trim sheet does not have a plastic bearing, protect bowl by applying a layer of masking tape where the bearing will ride.

If all the sheet excess is not removed, use an inflatable drum sander to remove excess.

C. “SOFT” SEAM UNDERMOUNT INSTALLATION

The procedures for installing undermount kitchen, bar/vanity sinks, and lavatories differ. Refer to the procedure that corresponds to the type of undermount sink or lavatory you are installing.

C.1. Undermount kitchen sinks

1. Prepare the bowl.
 - Check to see if the flange is flat and free of tool marks.
2. Prepare the support frame for kitchen sinks.
 - Measure the size of the kitchen cabinet opening where the sink will be installed.
 - Construct a plywood frame, allowing adequate clearance between the strips running front to back. These will support the sink. See recommended clearances on the templates.
 - Position the frame within the cabinet opening so that when the sink is installed, the top of the sink flange is level and flush with the top surface of the perimeter support at the cutout area.
 - Firmly attach the frame to the cabinet interior with screws (Figure C-1).

HELPFUL HINT:

There are commercially available support systems designed to support undermount sinks.

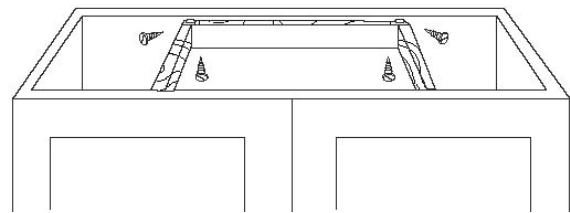

Figure C-1

3. Install the sink in the frame.
 - Place a 1" (25 mm) spot of silicone at each corner of the frame where it will contact the sink.
 - Gently position the sink within the frame (Figure C-2).
 - Check the sink flange for levelness and for proper mating height with the perimeter support at the cutout area. Adjust or shim, if needed.

SINKS AND LAVATORIES

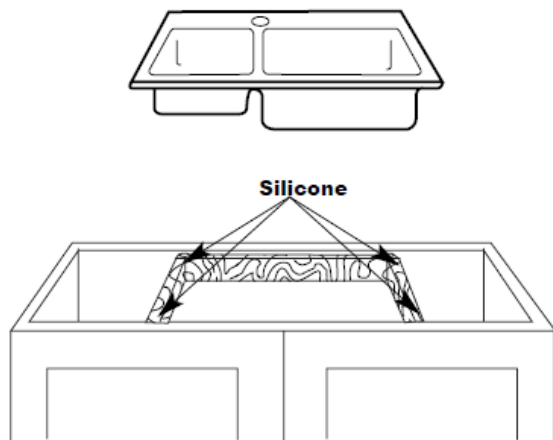

Figure C-2

4. Prepare the sheet.
 - Cut the DuPont™ Corian® sheet for the countertop to the proper length and width.
 - Trial-fit and adjust, if needed.
5. Position and secure the template for the cutout.
 - Carefully measure the countertop to determine the exact location of the cutout.
 - Clamp the template in position.
6. Rout the cutout.
 - Make the cutout using a 2-hp to 3-hp router with a 1" (25 mm) template guide and a $\frac{3}{8}$ " (10 mm) carbide-tipped, single-flute router bit (Figure C-3).
 - Rout the faucet holes. Faucet holes can be made using a hard template and router or a high-speed electric drill with a spade bit, twist drill or hole-saw. Do not use auger bits.
 - To minimize sanding, smooth the inside of the cutout with a $\frac{1}{2}$ " (13 mm) double-flute, carbide-tipped bit and a 1" (25 mm) template guide.
 - Remove the template.
 - Use an orbital sander to smooth the cutout area and to remove all router marks.
 - Rout decorative design into edge of cutout if desired.

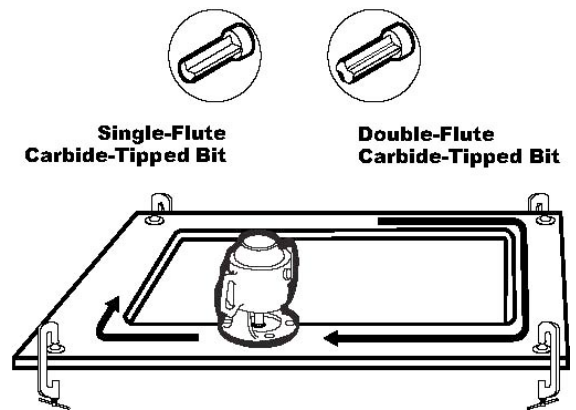

Figure C-3

7. Install the countertop over the sink.
 - Clean the top of the sink flange with denatured alcohol and a clean, white cloth (Figure C-4).
 - Clean the bottom of the countertop around the cutout area with denatured alcohol and a clean, white cloth.
 - Apply a generous bead of color-coordinated DuPont™ Surfaces Sealant around the top inside edge of the flange (where sink wall and flange meet).
 - Position the countertop over the sink, being careful that the DuPont™ Surfaces Sealant provides a complete seal where the surfaces meet.
 - Remove the excess sealant; then wipe the joint with denatured alcohol and a clean, white cloth.

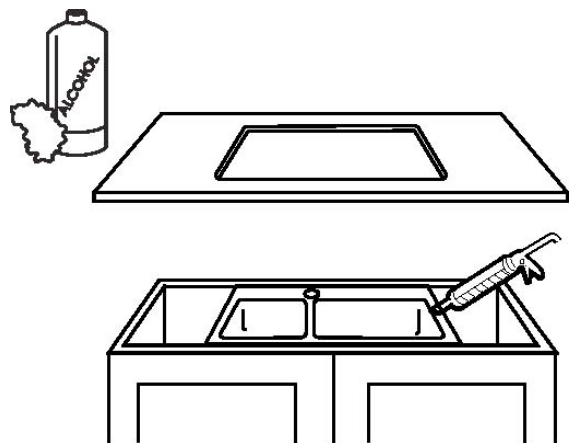

Figure C-4

Allow the silicone adhesive to cure overnight before installing plumbing connections.

SINKS AND LAVATORIES

C.2. Undermount bar/vanity sinks and lavatories

1. Turn DuPont™ Corian® sheet upside-down and position and secure the template for the cutout.

- Use a 2-hp to 3-hp router with a 1" (25 mm) template guide and a $\frac{3}{8}$ " (10 mm) carbide-tipped, single-flute bit (Figure C-5).
- Remove the template.
- Use an orbital sander to smooth the cutout if needed (Figure C-6).

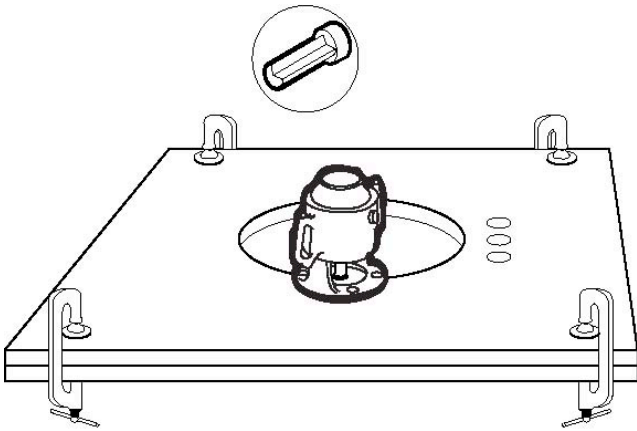

Figure C-5

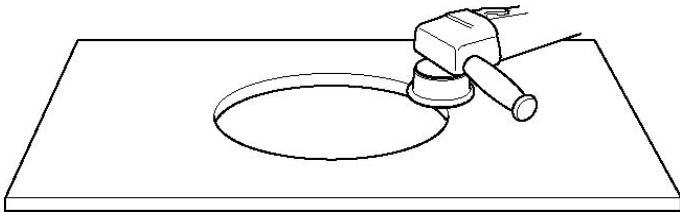

Figure C-6

2. Trial-fit the bowl.

- Position the bowl over the cutout, checking for a tight fit (Figure C-7).
- Modify and resand the DuPont™ Corian® sheet, if needed.

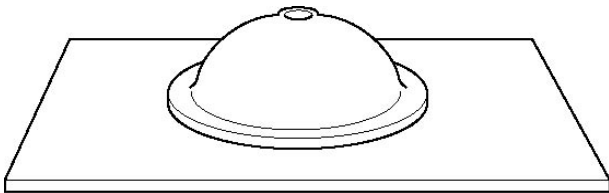

Figure C-7

3. Make the faucet holes.

- Use a template and a router or a high-speed electric drill equipped with either a spade bit, twist drill or hole saw.
- Do not use auger bits.

4. Install brass inserts.

- Center the bowl face-down over the cutout.
- Locate the holes 1" (25 mm) from the side edges of the bowl flange and away from the bowl's front and back edges to allow clips to clear the cabinet frame (Figure C-8).
- Drill holes $\frac{1}{4}$ " (6 mm) wide by $\frac{1}{4}$ " (6 mm) deep into the sheet (check brass insert instructions for exact hole dimensions).
- Remove the bowl and drive the brass inserts into the holes in the countertop, slotted end in first.

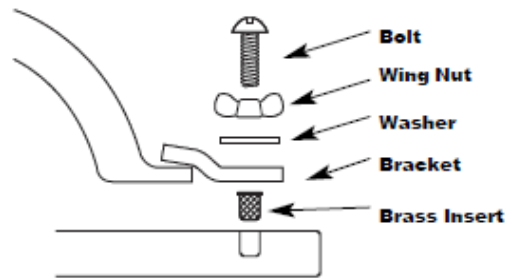

Figure C-8

5. Fasten the bowl to the top.

- Clean the bowl's top flange and the cutout with denatured alcohol and a clean, white cloth (Figure C-9).
- Assemble the undermount hardware (Figure C-8).
- Screw the bolt assemblies into the brass inserts.
- Apply a generous bead of color-coordinated DuPont™ Surfaces Sealant to the inside edge of the bowl flange.
- Install the bowl over the cutout.
- Tighten the wing nuts to secure the bowl.
- Make sure that the joint is completely filled, and then remove the excess sealant with denatured alcohol and a clean, white cloth.

SINKS AND LAVATORIES

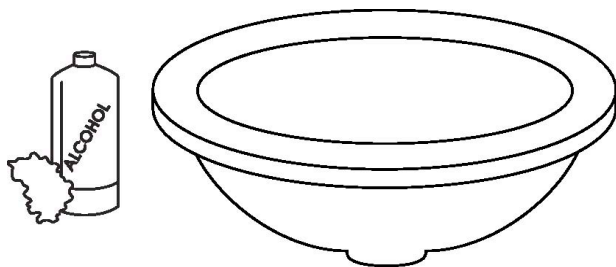

Figure C-9

Allow the silicone adhesive to cure overnight before installing the top or installing plumbing connections.

6. Install the DuPont™ Corian® countertop and sink on the cabinet.
 - Place a 1" (25 mm) spot of silicone adhesive every 12" (305 mm) around the top cabinet support (Figure C-10).
 - Position the bowl and countertop unit on the support.

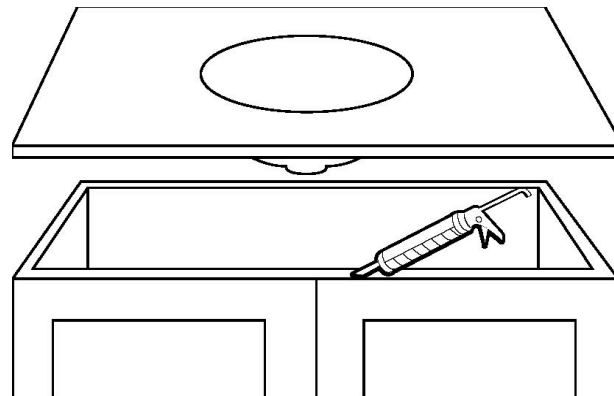

Figure C-10

D. REFERENCED DOCUMENTS

DuPont™ Corian® Solid Surface Fabrication/Installation Fundamentals – Approved Cleaning Solvents (K-25701)

This information is based on technical data that E.I. du Pont de Nemours and Company and its affiliates ("DuPont") believe to be reliable, and is intended for use by persons having technical skill and at their own discretion and risk. DuPont cannot and does not warrant that this information is absolutely current or accurate, although every effort is made to ensure that it is kept as current and accurate as possible. Because conditions of use are outside DuPont's control, DuPont makes no representations or warranties, express or implied, with respect to the information, or any part thereof, including any warranties of title, non-infringement of copyright or patent rights of others, merchantability, or fitness or suitability for any purpose and assumes no liability or responsibility for the accuracy, completeness, or usefulness of any information. This information should not be relied upon to create specifications, designs, or installation guidelines. The persons responsible for the use and handling of the product are responsible for ensuring the design, fabrication, or installation methods and process present no health or safety hazards. Do not attempt to perform specification, design, fabrication, or installation work without proper training or without the proper personal protection equipment. Nothing herein is to be taken as a license to operate under or a recommendation to infringe any patents. DuPont shall have no liability for the use of or results obtained from such information, whether or not based on DuPont's negligence. DuPont shall not be liable for (i) any damages, including claims relating to the specification, design, fabrication, installation, or combination of this product with any other product(s), and (ii) special, direct, indirect or consequential damages. DuPont reserves the right to make changes to this information and to this disclaimer. DuPont encourages you to review this information and this disclaimer periodically for any updates or changes. Your continued access or use of this information shall be deemed your acceptance of this disclaimer and any changes and the reasonableness of these standards for notice of changes.

© E.I. du Pont de Nemours and Company 2012. All rights reserved.

The DuPont Oval, DuPont™, The miracles of science™, and Corian® are trademarks or registered trademarks of E.I. du Pont de Nemours and Company ("DuPont") or its affiliates. K-25296 7/12